

# User guide

## Profoto B20/B30



## **Congratulations on your new Profoto product!**

Regardless if you chose a new flash or a new light shaping tool, know that more than half a century's worth of experience was put into its making.

If the years have taught us one thing, it is never to neglect a single detail. We only put our name on a product in which we have the fullest confidence. Before shipping, every one of our products passes an extensive and strict testing program. Unless it complies with the specified performance, quality and safety, it is a no-go.

As a result, we are confident that your new Profoto product will stay with you for years and help you grow as a photographer. But getting the product is only the beginning of that journey. Using it for light shaping is the real adventure for today and into the future. That is why we take pride in providing you such a wide assortment of light shaping tools and continuing to bring you the latest technology to our products, allowing you to shape the light in any way you can imagine, across any devices.

The almost infinite possibilities might seem bewildering at first, but we're certain you will soon get the hang of it.

Make sure you download our Profoto app and sign up to the MyProfoto account to manage your Profoto devices and stay updated with product news and updates. You'll also receive insights, tips and tricks from leading photographers on how to shape light; because we hope that sharing our experiences from over 50 years of light shaping will inspire you to grow even further.

Enjoy your Profoto product.

Conny Dufgran, founder

# General safety instructions

## IMPORTANT SAFETY INFORMATION & WARNINGS!



Do not operate the equipment before studying the Quick Start and Safety Guide and the User Guide for both the LST and the lamp heads. Make sure that the Quick Start and Safety Guide is always accessible to the user! Profoto products are intended for indoor condition use! Do not place or use the equipment where it can be exposed to moisture, extreme electromagnetic fields, or in areas with flammable gases or dust! Do not expose the equipment to dripping or splashing. Do not place any objects filled with liquids, such as vases, on or near the equipment. Should any water or pollutants such as ash, dust, or insects end up in the product, do not touch the equipment. Contact Profoto service! Do not expose the equipment to rapid temperature changes in humid conditions as this could lead to condensation water in the unit. Do not modify, disassemble, open, drop, crush, puncture, heat above 60°C (140°F), incinerate, or shred battery. Keep batteries (battery pack or battery installed) away from open flame and away from sunlight to prevent heat build-up. Risk of fires and burns, rupture and explosion, electrolyte leakage and/or venting. The emissions are toxic. Ensure adequate ventilation in case of battery leakage or gas release. Move exposed persons to fresh air and seek medical attention. Do not short-circuit the battery or its cells. In the event of a cell leaking, do not allow the liquid to come in contact with the skin or eyes. In the event of contact with skin or eyes: rinse immediately with fresh water and seek medical attention. Stop using the battery if it becomes hot, discolored, or deformed. Only use the intended Profoto charger(s) to charge the battery. Do not connect lights, or use light shaping tools, from other manufacturers. Always use protective gloves and safety glasses while performing maintenance on the flash equipment. Change the front lens if it becomes visibly damaged to such an extent that its effectiveness is impaired, for example by cracks or deep scratches. If the flash product enclosure should crack, immediately stop using the product and contact Profoto Service! It is unavoidable that the type of capacitor used in flash products can sometime break. If this happens, a sharp smell may be emitted from the flash product along with smoke. Avoid getting this emission in the face. If the emission should get in the eyes or mouth, rinse with water. The emission is nontoxic. Rinse with water and soap if you get leaking electrolyte on skin. Do not ingest the electrolyte. Always lift generators and lights by their handles and never by the connectors or cables. Do not connect or charge the battery, or otherwise operate a product that has been left in a hot or cold environment, such as a car. Let the product reach the approved operating temperature before doing so. Do not mount or use the equipment at a height exceeding 2 m (6.5 feet). When using a stand, always make sure that the equipment is securely attached. Remove transport cap from lamp head before use! Never install the product in a confined space. Always leave space around the product for ventilation, do not cover any ventilation openings! Do not obstruct ventilation by placing filters, diffusing materials, etc. over inlets and outlets of the equipment ventilation or directly over glass cover, modeling lamp, or flashtube! Do not expose product to excessive heat such as sunshine, heat sources, fire or similar. When adjusting the tilt on stand adapter, be aware of pinch risks to your hands.



This appliance is not intended for use by individuals (including children) with reduced physical, sensory, or mental capabilities, or by those lacking experience and knowledge, unless supervised or instructed on the proper use by a responsible person.

**WARNING - Electrical Shock - High Voltage!**

Do not attempt to repair this product yourself, as opening or removing screwed covers may expose you to the risk of electric shock. Equipment must only be serviced, modified, or repaired by authorized and competent service personnel! Warning: the terminals marked with the flash symbol are hazardous live. Do not open or disassemble flashes, generators, or lamp heads! Equipment operates with high voltage. The flashes, generators, or lamp heads can contain hazardous live, for a considerable time, even when powered off and/or the battery has been removed. Before replacing the flash tube and/or front glass, remove the battery from the device and wait at least 10 minutes. Use suitable electrically insulated pliers and screw drivers. Follow the specific instructions provided with the replacement part(s). The charger mains cable and plug serve as the disconnect device from mains power. Always disconnect the charger from the mains outlet by pulling the plug, not the cable. The socket outlet should be in close proximity to the equipment and should be easily accessible. Never operate the equipment without a functioning flashtube and/or modeling light.

**Warning - Loud Noise.**

There is a risk of exposure to sudden loud noise. Please use hearing protection and/or observe a minimum safety distance of 26 cm (10 in.) (B20), 34 cm (13 in.) (B30) between the generator and users/other people present.

**Caution!**

Possibly hazardous optical radiation emitted from this product. Do not stare at operating lamp. May be harmful to the eye. Do not trigger a flash towards a subject who is not expecting the flash, any person operating heavy equipment, or anyone performing any other activities where an unexpected flash could cause injury or harm. Please note that flashes can be triggered remotely from a long distance.

**Caution - Burn Hazard - Hot Parts!**

Do not touch hot parts with bare fingers! Modeling lamps and flash tubes may make certain metal parts, front lenses, or glass covers emit strong heat when used! All lamps may on rare occasions explode and throw out hot particles! Do not point modeling lamps or flashtubes too close to people.

**NOTICE Note about RF!**

This equipment makes use of the radio spectrum and emits radio frequency energy. Make sure the device is operated according to local regulations. The frequency spectrum used by this device is shared with other users. Interference cannot be ruled out. Regulations change from time to time, so please make sure you are using the latest firmware and instructions to ensure compliance with rules and regulations. The firmware can be updated using the Profoto app. According to RF exposure regulations, under normal operations the end user shall refrain from being closer than 20 cm from the device.



# Table of Contents

General safety instructions.....	4
Nomenclature .....	9
Getting started.....	12
Mandatory safety instructions .....	12
Powering up the unit.....	13
Product registration and firmware update.....	13
Charge the battery.....	14
Charge temperature.....	14
Discharge temperature .....	15
Battery storage .....	15
Check the battery status .....	15
Mount the battery .....	16
Attach the stand adapter.....	17
Setup on light stands.....	18
Mount Profoto Light Shaping Tools.....	19
Basic operation.....	21
Switch on/off.....	21
Indicators .....	21
Adjust the flash power.....	22
Adjust the continuous light .....	22
B20/B30 unit states.....	24
Settings.....	26
Air group.....	26
Air channel.....	26
Air .....	27
Bluetooth .....	27
IR Sync .....	27
Flash mode .....	27
Continuous light .....	28
General settings .....	29
Connectivity .....	32
Set up connectivity with Profoto remotes.....	32
Profoto apps .....	33

Maintenance.....	34
Care instructions.....	34
Replacing front glass/flash tube.....	34
Other.....	35
Overheat protection.....	35
Serial number.....	35
Technical specifications.....	36
Warranty.....	39
Credit.....	39

# Nomenclature

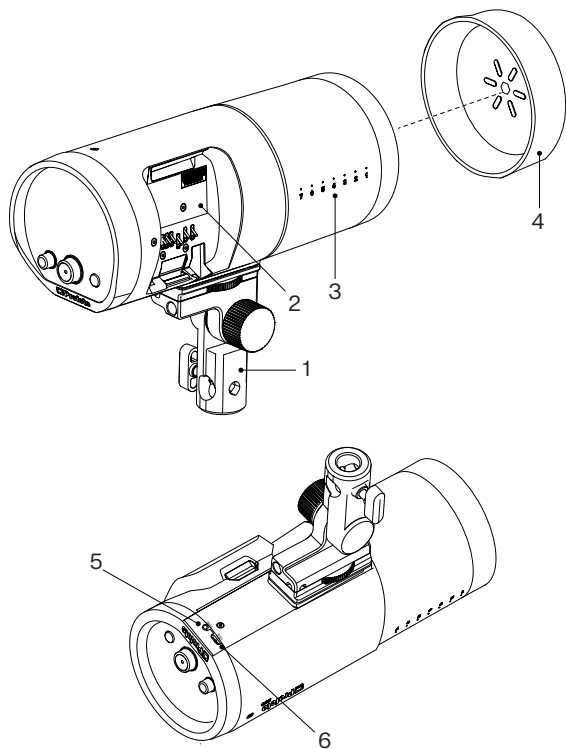

- |                        |                  |
|------------------------|------------------|
| 1. Stand adapter       | 4. Transport cap |
| 2. Battery compartment | 5. Sync port     |
| 3. Zoom scale          | 6. USB           |

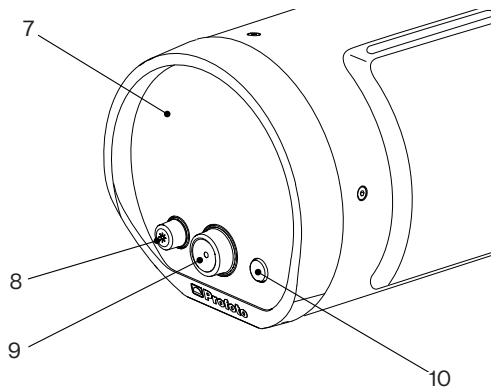

- |                          |                          |
|--------------------------|--------------------------|
| 7. Display               | 9. Centerdial            |
| 8. Continuous light dial | 10. Test & ON/OFF button |

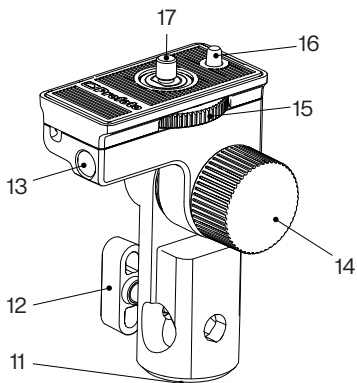

- |                      |                            |
|----------------------|----------------------------|
| 11. Stand stud mount | 14. Tilt-lock knob         |
| 12. Clamp screw      | 15. Attachment screw wheel |
| 13. Umbrella holder  | 16. Alignment pin          |
|                      | 17. Attachment screw       |

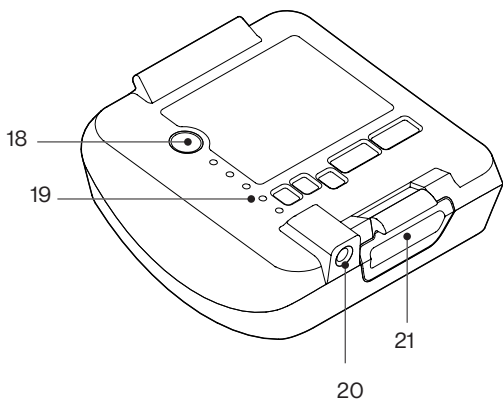

18. Battery status button

19. Battery status LEDs

20. Battery charge connector

21. Battery release button

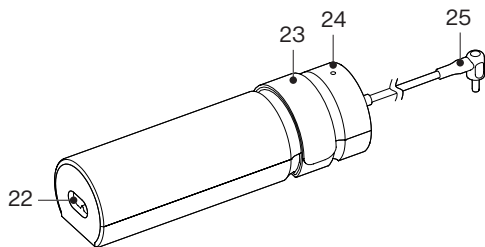

22. AC inlet

23. Strap

24. Charge status indicator

25. Battery connector plug

# Getting started

## Mandatory safety instructions

### Flash Equipment Safety Brief

#### Transport & handling

Cap and Power Off: Before transportation, turn off the unit, mount the transport cap, and disconnect from mains power and/or remove the battery if applicable.

12

Safe transport: Always use the provided case to prevent damage during transport.

#### Before use:

Inspect: Before connecting to mains and/or inserting the battery, check the housing and front glass for cracks.

#### In the event of equipment damage

Stop use and disconnect: If there are any open cracks in the housing or front glass, immediately stop use, disconnect from power and/or remove the battery to prevent electric shock risk. Do not touch any internal parts and contact Profoto Service or an authorized service center for assistance.

#### High voltage warning

Persistent voltage: High internal voltage remains up to 10 minutes after the unit is turned off and disconnected from battery or mains. Never remove front glass or touch any parts inside without referring to the complete user guide and Quick Start and Safety Guide.

#### Self-maintenance

Caution with maintenance: Refer to the complete user guide and Quick Start and Safety Guide and wear protective gear for any allowed self-maintenance activities, such as replacing the front glass or flashtube.

#### Repairs

Authorized service only: Any repairs beyond basic self-maintenance must only be performed by authorized service personnel. For assistance, contact Profoto Service or an authorized service center.

In addition to this user guide, you are required to read the Quick Start and Safety Guide before you start using your B20/B30. It contains vital information for the safe operation of the product as well as important regulatory information. The Quick Start and Safety Guide is supplied in print with the B20/B30, translated into many languages. It can also be found for download where you downloaded this user guide.

## Powering up the unit

1. Charge the battery completely.
2. Mount the battery in the unit's battery compartment [2].
3. Press and hold the test button [10]. The unit starts and the display lights up.
4. Register and update the firmware on the unit.

## Product registration and firmware update

Before using your product for the first time, please register and update the product. Scan the QR code below or go to [profoto.com/setup](https://profoto.com/setup) for additional instructions.

**Register your light  
for extra warranty**



[profoto.com/setup](https://profoto.com/setup)

## Charge the battery

### NOTE!

New battery must be fully charged before first use.

The battery can be charged from any charge level. Only use the Profoto charger supplied with the B20/B30 or other chargers recommended by Profoto.

1. Connect the battery connector plug [25] on the battery charger to the battery charge connector [20] on the battery.
2. Connect the battery charger to mains power.
3. Check that the charger indicator [24] is continuously amber, indicating that charging is in progress.
4. When charging is completed, the charger indicator [24] turns green. When not charging, it is recommended to disconnect the battery charger from mains power and from the battery.

### NOTE

- Disconnect the battery from the power outlet before cleaning or when not in use.
- Battery should not be left discharged for a longer period of time. If the battery is deeply discharged, the charging time may be longer than specified in the section Technical Data.
- Battery should not be charged while in contact with flammable material, such as textiles.
- Do not attempt to recharge a battery that has been left in a hot or cold environment, such as a car. Let the battery reach a temperature suitable for charging before doing so.

## Charge temperature

Charge the battery in a temperate indoor environment (about 20°C/70°F).

The battery can be charged in a wider temperature range (0 – 45°C / 32 – 113°F), but charging at high or low temperatures may increase the charging time and/or reduce the battery lifetime.

## Discharge temperature

The battery has a built-in temperature protection that disables battery function if the battery is too cold or too hot. Once the battery temperature reaches between  $-7^{\circ}\text{C}/19^{\circ}\text{F}$  and  $52^{\circ}\text{C}/125^{\circ}\text{F}$ , the battery will start working again.

## Battery storage

If the battery is to be stored for a longer period of time, it should be charged half-full before storage. Never store an empty battery for a longer period, as it may go into a deep discharge state that can damage the battery cells. After storing a battery for more than 6 months without using it, it is advised to check the charge level on the battery. If fewer than 2 of the battery status LEDs [19] light up, the battery should be charged to half-full again before further storage.

Temperate and dry indoor environment (about  $20^{\circ}\text{C}/70^{\circ}\text{F}$ ). The storage environment should be free from dust and corrosive gas.

For short-term storage, the battery can be stored at up to  $45^{\circ}\text{C}/113^{\circ}\text{F}$  and higher charge levels.

## Check the battery status

The battery charge can be checked on the battery itself by pressing the battery status button [18].

While the battery status button is pressed, the battery charge status is indicated by the battery status LEDs [19]:

5 LEDs:	75-100%
4 LEDs:	50-75%
3 LEDs:	25-50%
2 LEDs:	10-25%
1 LED:	<10%:

Once the B20/B30 is turned on, the battery charge status is indicated by the battery icon  in the bottom right of the display [7]:

4 sections: 75-100%

3 sections: 50-75%

2 sections: 25-50%

1 section: 10-25%

Empty frame: <10%

## 16

If the B20/B30 is turned on and the battery is charged during use, it will be indicated by a battery charge icon  in the bottom right of the display [7].

### Mount the battery

1. To mount the battery, fit the battery into the B20/B30 unit as illustrated below and press firmly until you hear a “click” sound, indicating that the battery is locked in place.
2. To dismount the battery, first, switch off the B20/B30 unit. Then press the battery release button [21] and pull out the battery.

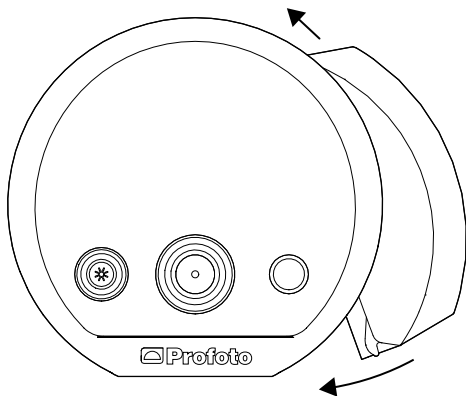

## Attach the stand adapter

Attach the stand adapter to the stand adapter attachment point on the B20/B30.

1. Before attaching, observe that the alignment pin on the stand adapter fits into the alignment pin hole on the B20/B30.
2. Tighten the attachment screw with the attachment screw wheel [17] until the stand adapter sits firm.

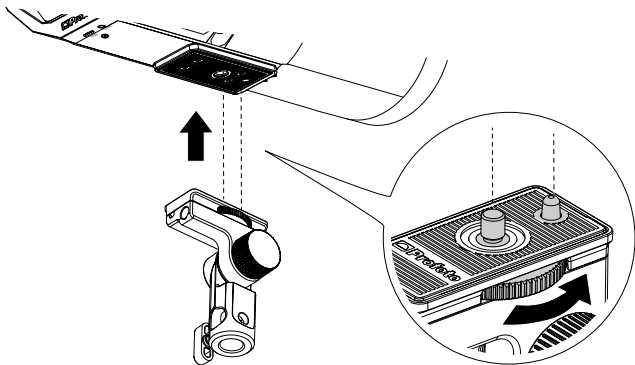

## Setup on light stands

To mount the B20/B30 onto a light stand, follow the instructions below.

1. Fit the stand adapter to the light stand and secure it with the clamp screw [12].
2. Loosen the Tilt-lock knob [14] to adjust the tilt position.
3. Tighten the Tilt-lock knob [14] to lock the tilt position.

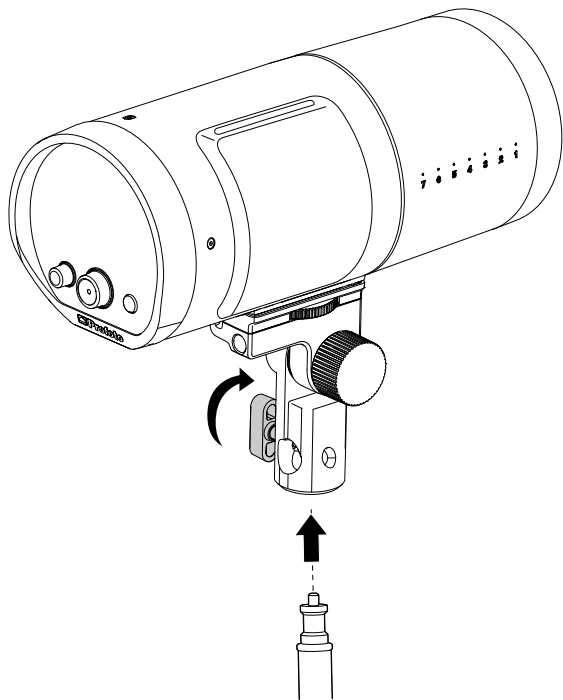

## Mount Profoto Light Shaping Tools

The B20/B30 unit has a built-in reflector that creates a wide and even light spread with a high output. In addition, the unit is compatible with more than 120 light shaping tools, which can be used to shape its already beautiful light into almost any light you can imagine.

### Mount tools with standard reflector mount (rubber collar with clasp)

Most reflectors are equipped with Profoto's unique clamp mechanism. This makes them easy to mount and allows you to shape the light by simply sliding the reflector back and forth along the zoom scale [3] on the unit.

1. Unlock the clasp on the reflector.
2. Slide the reflector onto the front of the B20/B30. Use the zoom scale [3] as a memo for where to position the reflector.
3. Secure the reflector by locking the clasp on the reflector.

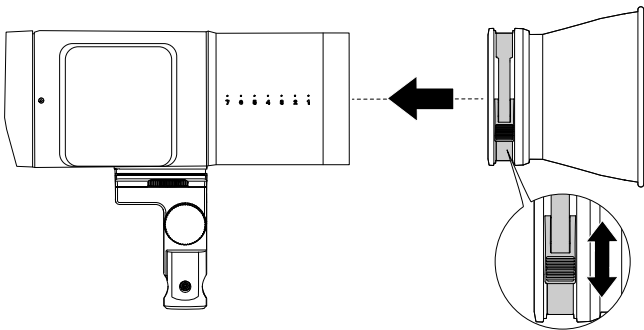

## Mount umbrellas

The umbrella holder is integrated into the stand adapter. Umbrellas are easily mounted by sliding the umbrella shaft into the umbrella holder [13]. The umbrella shaft diameter must be between 7 mm and 8 mm to fit into the umbrella holder.

1. Mount the stand adapter on the unit.
2. Slide the umbrella shaft into the umbrella holder [13] passing the point where you feel some friction.
3. Continue to slide the umbrella shaft into the umbrella holder [13] until the umbrella is positioned where you want it to be.

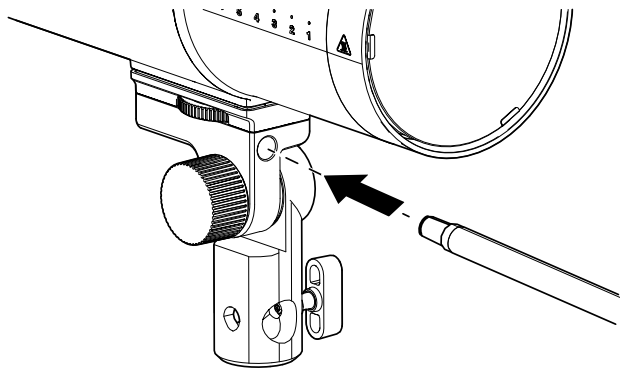

## Basic operation

### Switch on/off

1. To switch on the unit, press and hold the Test button [10].
2. To switch off the unit, press and hold the Test button [10].

When the unit is switched off, the current settings are stored and will apply when the unit is switched on again.

#### NOTE

The unit automatically enters a sleep mode after a period of inactivity. The period of inactivity for the sleep function is selectable via the settings menu.

## Indicators

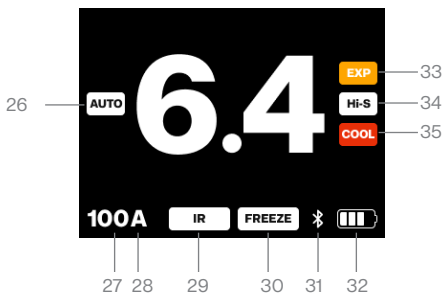

- |                             |                         |
|-----------------------------|-------------------------|
| 26. Auto (TTL flash update) | 31. Bluetooth           |
| 27. Air channel             | 32. Battery             |
| 28. Air group               | 33. Exposure warning    |
| 29. IR Slave                | 34. HSS                 |
| 30. Flash mode              | 35. Overheat protection |

## Adjust the flash power

The flash power setting (light output) is shown in big bold numbers on the display [7]. The power scale is a relative f-stop scale from 0.1-10. The maximum light output is shown as 10.

Use the Center dial [9] to change the flash light output:

- Turn the Center dial [9] to change the light output in 1/10 f-stop increments.
- Press and turn the Center dial [9] to change the light output in increments of 1f-stop.
- Press the Test button[10] to release a test flash.

## Adjust the continuous light

The continuous light can be set to FREE or PROPORTIONAL (factory setting) in the settings menu.

1. When set to FREE, the continuous light brightness can be adjusted separately from the flash power.
2. When set to PROPORTIONAL, the continuous light brightness is always proportional to the flash power.

### Adjusting the continuous light when it is set to FREE

1. Press the Continuous light dial [8] to turn the continuous light on or off.
2. When the continuous light is on, the brightness and color temperature are indicated in the display by two separate bars.



3. Turn the Continuous light dial [8] to change the brightness.

## Adjusting the continuous light when it is set to PROPORTIONAL

1. Press the Continuous light dial [8] to turn the continuous light on or off.
2. When the continuous light is on, the brightness and color temperature are indicated as shown below, with the mode label "PROPORTIONAL"

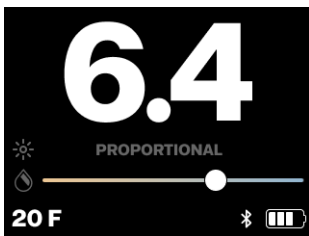

3. Turn the Center dial [9] to change the intensity. This will change both flash and continuous light proportionally.

## Adjusting the Color temp

1. Press and turn the Continuous light dial [8] to change the color temperature.

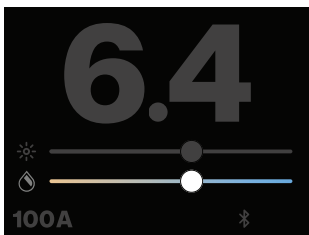

## B20/B30 unit states

In addition to the normal operating state which has been described thus far, the unit has three other states.

### Sleep

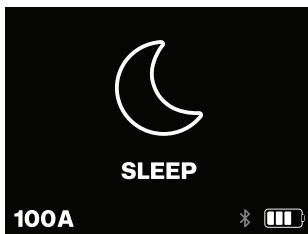

The unit automatically enters a sleep state after a period of inactivity. The inactivity duration for the sleep function is selectable via the settings menu. If the continuous light is ON, the unit will not go into a sleep state.

During the sleep state, certain functions and backlights are turned off to conserve power. However, Air and Bluetooth (Bluetooth Low Energy) connections remain active. The unit returns to the normal state if any interaction is made manually, through the app, or via a Profoto remote.

### Head off

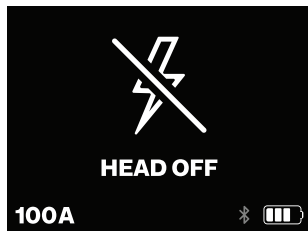

The unit can only enter a "Head Off" state by selecting "Head Off" from either the remote or app. When in the Head Off state, the flash function and continuous light are turned off.

The unit returns to the normal state if “Head On” is selected from the remote or app, or by pressing any button or turning any knob/wheel on the unit. Upon returning to the normal state, the unit reverts to the same flash energy and continuous light settings it had before the “Head Off” state was activated.

## Mobile capture



When the unit is connected to the Profoto Camera App with the camera view active, it enters the “Mobile Capture” state.

During this state, it is not possible to control energy or continuous light on the unit. The Center dial [9] can be pressed to access the Settings menu, and pressing the Test button [10] will trigger the camera to take an image. The unit returns to the normal state when the camera view is deactivated in the Profoto Camera App.

## Settings

All B20/B30 settings are accessed and selected through the settings menu.

1. Press the Center dial [9] to enter the settings menu.

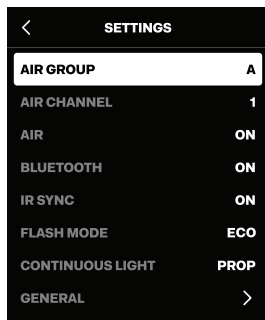

2. Scroll through the settings menu by turning the Center dial [9].
3. To change a setting, press the Center dial [9]. For some settings, a sub menu will appear.
4. To return to the previous menu, press the Continuous light dial [8] or select the left arrow symbol at the top of the menu.
5. To return to the main screen, press the Test button [10].

### Airgroup

The AIR GROUP setting is used to select the group (A-F) for wireless control via Profoto Air. Factory default is group A.

#### NOTE

The AIR GROUP setting is only selectable when AIR is set to ON.

### Airchannel

The AIR CHANNEL setting is used to select the channel (1-100) for wireless triggering via Profoto Air. Factory default is channel 1.

#### NOTE

The AIR CHANNEL setting is only selectable when AIR is set to ON.

## Air

The AIR setting can be set to ON or OFF to activate or deactivate Profoto Air wireless functionality. Factory default is ON.

## Bluetooth

The BLUETOOTH setting is used to manage connectivity with the Profoto app. See also section Profoto app connectivity. Factory default is ON:

- ON: Bluetooth is activated and the unit can be connected to the Profoto app.
- CONNECTED: The unit is connected to Profoto app.
- OFF: Bluetooth is deactivated.

### NOTE

When the unit is CONNECTED, the DISCONNECT option is selectable.

## IR Sync

The IR Sync setting can be set to ON or OFF to activate or deactivate the infrared slave sensor. Factory default is OFF.

### NOTE

It is highly recommended to set IR Sync to OFF if other methods of triggering (e.g AIR) are used.

## Flash mode

The FLASH MODE setting adjusts the flash duration and color temperature on the flash across the full power range. There are three selectable settings: ECO, BOOST and FREEZE. Factory default is ECO:

- ECO: (No indicator shown on display)  
ECO mode is the default setting recommended for most cases. It is optimized for color temperature consistency and maximized equipment lifetime.
- BOOST: BOOST indicator shown on display  
BOOST mode is similar to ECO flash mode but boosted for a little more max light output. The general recommendation is to

only use BOOST mode temporarily in cases where the extra light output is needed.

- **FREEZE:** FREEZE indicator shown on display  
FREEZE mode is useful when extremely short flash duration is needed to capture splashing liquid or powder shots without motion blur. Note that the flash color temperature in FREEZE mode will vary much more across the power range compared with ECO and BOOST flash modes.

## 28

### NOTE

Flash mode settings are only effective when the flash is used within the camera's X-Sync shutter speed range. When shooting at faster shutter speeds, the camera automatically enables High-Speed Sync mode, which cannot be manually selected.

## Continuous light

The CONTINUOUS LIGHT setting defines how the continuous light intensity is adjusted. There are two selectable settings. Factory default is PROP:

- **PROP:** The continuous light intensity is always proportional to the flash power setting. This setting is recommended if the continuous light is used as modeling light.
- **FREE:** The continuous light intensity can be set independently of the flash power setting. This setting is recommended if the continuous light is used as video light.

### NOTE

For instructions on how to adjust the continuous light when either PROP or FREE is selected, go to the section "Adjust the continuous light".

## General settings

### Ready signal

The READY SIGNAL setting sets how the unit indicates that it is fully recycled after a flash and is ready to flash again. There are four selectable settings. Factory default is SOUND use same style throughout:

- **SOUND:** The unit beeps when it has recycled and is ready to flash.
- **DIM:** The continuous light turns off after flashing and turns on when the unit has recycled and is ready to flash.
- **SOUND & DIM:** The unit signals with both SOUND and DIM.
- **OFF:** The unit doesn't signal that it is ready to flash.

#### NOTE

The test button indicator light always turns off after flash and turns on again when the unit is fully recycled.

### Control sounds

The CONTROL SOUNDS setting can be set to ON or OFF to enable/disable tactile sounds for control knobs and buttons. Factory default is ON.

### Warning sounds

The WARNING SOUNDS setting can be set to ON or OFF to enable/disable the wrong exposure alarm. Factory default is ON.

#### NOTE

The EXP indicator will always appear temporarily on the display [7] in case of a wrong exposure alarm, regardless of the warning sound setting.

### Display brightness

The DISPLAY BRIGHTNESS setting is used to set display brightness. There are three selectable settings. Factory default is AUTO:

- **AUTO**
- **MAX**
- **MEDIUM**
- **LOW**

## Auto sleep

The AUTO SLEEP setting sets a timer for a period of inactivity until the unit goes into sleep mode to save energy. There are four selectable settings. Factory default is 30 MIN:

- 5 MIN: The unit goes into sleep mode after 5 minutes of inactivity.
- 30 MIN: The unit goes into sleep mode after 30 minutes of inactivity.
- 1 HOUR: The unit goes into sleep mode after 1 hour of inactivity.
- NEVER: The unit never goes into sleep mode.

## Auto off

The AUTO OFF setting allows for configuration of timer which turns off the unit after a period of inactivity. The factory default is 1 HOUR.

- 15 MIN: The unit turns off after 15 minutes of inactivity.
- 1 HOUR: The unit turns off after 1 hour of inactivity.
- NEVER: The unit never turns off.

## Display orientation

The DISPLAY ORIENTATION setting changes the way information is displayed on the unit. There are three selectable settings. Factory default is AUTO:

- AUTO: The display orientation is automatically adjusted based on the unit's orientation.
- NORMAL
- REVERSED: The display is upside down for use when the flash is hanging from the ceiling.

## Unit stats

The UNIT STATS section displays lifetime accumulated unit stats. Flash count (number of triggered flashes), Runtime (hours in operation) and Power-on count (number of sessions).

## About

The ABOUT section displays unit-specific information about the serial number, hardware, and installed firmware.

## **Regulatory info**

The regulatory info section displays regulatory information.

## **Factory reset**

FACTORY RESET will reset all settings to factory default settings.

## Connectivity

The B20/B30 comes with built-in Profoto AirX connectivity. AirX is the 3rd generation of wireless Profoto connectivity, after Air and AirTTL.

AirX supports:

- Wireless Air and AirTTL functionality in Profoto Air and AirTTL-enabled remotes.
- Dedicated AirX functionality in AirX-enabled Profoto remotes and apps.

### Set up connectivity with Profoto remotes

These instructions only cover the basic setup on the B20/B30. For detailed operating instructions, refer to the user guide for your Profoto remote.

1. In the B20/B30 settings menu, set Air to ON.
2. In the B20/B30 settings menu, select the same channel that is set on your Profoto remote.
3. In the B20/B30 settings menu, assign a group (A-F).

### Auto (TTL) with Profoto remotes

Auto (TTL) requires no additional setup on the unit, once the Air channel and group setup are done. Just switch between Auto (TTL) and Manual (MAN) on your Profoto remote to select if you want the remote to adjust the flash automatically or if you want to control it manually.

The B20/B30 will keep the flash power set by Auto (TTL) when you switch the remote to Manual (MAN). This makes it easy to use Auto (TTL) as your “light meter” to get a good starting point for manual adjustments.

When Auto (TTL) is activated by the remote, the **AUTO** indicator temporarily appears on the display [7].

When an Auto (TTL) group adjustment is made on the remote, the **AUTO** indicator, including the offset, temporarily appears on the display [7].

### High-Speed Sync (Hi-S) with Profoto remotes

High-Speed Sync (Hi-S) requires no additional setup on the unit, once the Air channel and group setup are done. High-Speed Sync is activated on your remote or camera.

When High-Speed Sync is activated by the remote, the **Hi-S** indicator temporarily appears on the display [7].

### Profoto apps

Profoto apps are continuously updated with new functionality and help you keep your B20/B30 up to date with the latest new feature updates and bug fixes.

Some benefits of the Profoto apps are:

- Easy registration and updates. Register ownership and get the latest B20/B30 updates available at your fingertips.
- Smart remote control. Control the B20/B30 from your smartphone screen.
- Smartphone camera. Shape your smartphone images with a real flash.

Profoto apps are available on App Store, Google Play, and Huawei AppGallery. For more information about the Profoto apps, go to [profoto.com](http://profoto.com).

To connect the Profoto app to the B20/B30, you need to activate Bluetooth (see section Bluetooth). Then start the Profoto app and follow the in-app instructions.

## Maintenance

### Care instructions

To clean the unit, wipe with a soft cloth moistened with a little mild detergent. Use another soft, dry cloth to wipe dry.

### Replacing front glass/flash tube

#### **WARNING - Electric Shock - High Voltage!**

Remove the battery from the device and wait at least 10 minutes to let the unit discharge internal high voltage before removing the protective front glass. Always use protective gloves and safety glasses when replacing the flash tube and/or front glass. Never touch or try to replace the flash tube if the glass is cracked.

Removing the flashtube:

1. Remove the front glass [38] by pushing it gently while simultaneously pressing one glass spring towards the metal cylinder using a small flat head screwdriver (or similar).
2. Unfold the sheet metal ribbon pinching the flashtube spring [36] using pliers (or similar).
3. Insert a cable tie (or similar) behind the flashtube [37].
4. Pull out the flashtube [37] using the cable tie.

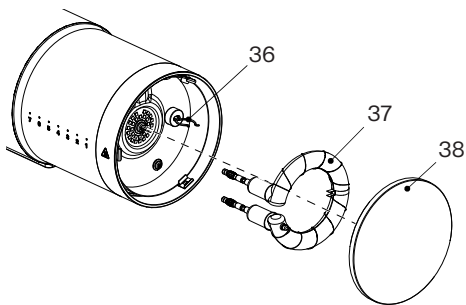

36. Flashtube spring

38. Front glass

37. Flashtube

Adding a flashtube:

1. Insert the flashtube contact pins into the protruding white sockets. Apply pressure manually on the glass surfaces above the flashtube legs to avoid any risk of damage. Push the flashtube [37] all the way to the bottom. Make sure the flashtube spring [36] passes inside the ribbon.
2. Pinch the ribbon around the flashtube spring [36] and fold it towards the glass.
3. Place the front glass [38] on two spring surfaces and push it until pinched in both areas. The frosted glass surface should face outwards. If the frosted glass is placed inward, it may cause burn marks on the glass. Force the third spring towards the metal cylinder using the screwdriver, then push the front glass [38] inwards until lodged between all springs.

## **Other Overheat protection**

A temperature limit indicator is shown on the main screen of the display [7] if the unit has reached a temperature level that has activated the built-in overheat protection. When this occurs, performance is limited until the temperature returns to an acceptable level.

## **Serial number**

The serial number is printed in the battery compartment [2]. You can also find the serial number in the display [7] under SETTINGS>GENERAL>ABOUT.

## Technical specifications

---

<b>Model name</b>	B20/B30
<b>Regulatory model</b>	PCA1608/PCA1609
<b>Operating temperature</b>	0°C to +35°C / +32°F to +95°F
<b>Storage temperature</b>	Store in normal indoor conditions
<b>Battery/cell designation</b>	41NR19/66
<b>Battery voltage (nominal)</b>	14.4 Vdc
<b>Rated capacity</b>	3.0 Ah
<b>Battery charging/discharging temperature</b>	0°C to +45°C / -20°C-60°C +32°F to +113°F / -4°F to 140°F
<b>Input power (battery charger)</b>	100-240 Vac, 50-60 Hz, 1.2A max. Output 16.8V --- 3.0A.

---

More technical specifications are available on [Profoto.com](http://Profoto.com).

<b>B20</b>		<b>Flash duration</b>					
		<b>ECO</b>		<b>BOOST</b>		<b>FREEZE</b>	
<b>Energy (scale)</b>	<b>Energy (Ws)</b>	<b>t0.5(s)</b>	<b>t0.1(s)</b>	<b>t0.5(s)</b>	<b>t0.1(s)</b>	<b>t0.5(s)</b>	<b>t0.1(s)</b>
10	250	1/1500	1/500	1/1500	1/500	1/1500	1/500
9,0	125	1/1600	1/600	1/1600	1/600	1/2000	1/1600
8,0	63	1/1800	1/700	1/12400	1/700	1/4600	1/3000
7,0	31	1/2100	1/800	1/14400	1/700	1/8700	1/4500
6,0	16	1/2800	1/1000	1/13100	1/900	1/11400	1/5700
5,0	8	1/3600	1/1300	1/3600	1/1300	1/14100	1/6800
4,0	4	1/4300	1/2000	1/4200	1/2000	1/18000	1/8600
3,0	2	1/5300	1/4100	1/5500	1/4200	1/20500	1/8900
2,0	1	1/7600	1/5200	1/7700	1/5300	1/21100	1/10500
1,0	0,5	1/11300	1/6400	1/11900	1/6600	1/27200	1/11000
0,1	0,2	1/14500	1/10800	1/15200	1/10300	1/38100	1/11700

<b>B30</b>		<b>Flash duration</b>					
		<b>ECO</b>		<b>BOOST</b>		<b>FREEZE</b>	
<b>Energy (scale)</b>	<b>Energy (Ws)</b>	<b>t0.5(s)</b>	<b>t0.1(s)</b>	<b>t0.5(s)</b>	<b>t0.1(s)</b>	<b>t0.5(s)</b>	<b>t0.1(s)</b>
10	500	1/900	1/300	1/900	1/300	1/900	1/300
9,0	250	1/1100	1/350	1/1100	1/350	1/1100	1/1000
8,0	125	1/1200	1/700	1/1200	1/700	1/2600	1/1900
7,0	63	1/1300	1/800	1/1300	1/800	1/5400	1/3100
6,0	31	1/1600	1/1100	1/1600	1/1200	1/8800	1/4400
5,0	16	1/3000	1/1600	1/3000	1/1700	1/12000	1/5600
4,0	8	1/3500	1/1900	1/3500	1/2000	1/15000	1/6900
3,0	4	1/5000	1/2600	1/5000	1/2600	1/18000	1/8300
2,0	2,0	1/8000	1/3800	1/9000	1/4000	1/19000	1/8500
1,0	1,0	1/10000	1/4800	1/12000	1/5300	1/20000	1/9000
0,1	0,5	1/10700	1/5000	1/13800	1/6200	1/21100	1/9800

More technical specifications are available on [Profoto.com](http://Profoto.com).

## Warranty

All generators, heads and remote controllers manufactured by or for Profoto which bear the Profoto trademark, name, or logo are individually tested before they leave the company and guaranteed for a period of two years with the exceptions set out in the Warranty terms. If you have any technical problems with the product, please contact an authorized Profoto service station or visit: <https://profoto.com/support/warranty>.

## Credit

App Store is a trademark of Apple Inc., registered in the U.S. and other countries and regions.

Google Play and the Google Play logo are trademarks of Google LLC.

HUAWEI and AppGallery are trademarks of Huawei Technologies Co., Ltd registered in China and other countries.

The Bluetooth word mark and logos are registered trademarks owned by the Bluetooth SIG, Inc. and any use of such marks by Profoto is under license.

USB Type-C and USB-C are registered trademarks of USB Implementers Forum.

Other trademarks and trade names are those of their respective owners.





Profoto AB  
Box 1264,  
172 25 Sundbyberg  
Sweden

+46 (0) 8 447 53 00  
info@profoto.com  
www.profoto.com



Technical data and product information are subject to change without notice.

May 2026.M0009195-001 RevB. Printed in Sweden.